

Series 228

Installation, Operation and Maintenance Manual



Table of Content

Description	Section
Introduction	1
Design	2
Installation	3
Operation	4
Disassembly Procedures	5
Assembly Instructions	6
Testing	7
Cycling of Infrequently Used or Stored Actuators	8
Bill of Materials	9
Spare Parts	10
Service	11

1. Introduction

The following Installation & Operation Manual will be a living document and will continuously be updated as the implementation of the 3K Rack & Pinion Actuators occurs. If you have any questions on the 3K Rack & Pinion Actuators, please contact ASC Engineered Solutions.

2. Design

The design of 3K Rack & Pinion Actuators are very similar to previous generation 2K Rack & Pinions Actuators. To support customers that will be replacing an existing 2K Rack & Pinion Actuator with a 3K Rack & Pinion Actuator, all mounting and stem receiver sizes have remained the same.

Key differences that have changed between generations:

- Addition of 3K700, 3K1000, 3K2400, 3K2700 and 3K3300
 - Note: 3K2400, 3K2700 and 3K3300 model sizes are rack and pinion and NOT scotch yoke design. Weight of the 3K Rack & Pinion Actuators has decreased compared to 2K Rack & Pinion Actuators.
- Various dimensions changes.
- Torques for both the Double Acting and Spring Return models have changed

3. Installation

3.1 Installation on Valves

Actuators are mounted directly to valves or adapted to the valve by means of an intermediate bracket and coupler. The coupler adapts the output of the actuator to the valve shaft. Standard mounting kits provide mounting of the actuator in the direction of the pipe. Pipelines can be horizontal, vertical, or other positions. When mounting the actuator to a valve using a mounting kit, the pinion drive, coupling device and valve stem should be centered and concentric to prevent any side loading to the bottom pinion radial bearing and valve stem seal area. After mounting, it may be necessary to adjust the end of travel stop for proper open or closed valve position. Pneumatically stroke the actuator several times to assure proper operation with no binding of the coupler.

3.2 Air Supply

Pneumatic piping to the actuator and associated accessories should follow the best practices for instrument pneumatic piping systems:

- Line shall be free of water, oil, pipe sealant or other contaminants.
- Operating medium is to be filtered dry air or inert gas which is filtered to 50-micron particles size or less.
- Actuator shall be supplied with proper air pressure and air volume.
- 3K Rack & Pinion Actuators shall not exceed a maximum working pressure of 150 psi.
- Spring Return Models
 - Note: If exhaust port is not piped, it is important that the exhaust port is not exposed to a corrosive atmosphere.

Please contact ASC Engineered Solutions for possible solutions if non-typical condition exists.

3.3 Lubrication

3K Rack & Pinion Actuators are lubricated from the factory and no additional lubrication is required unless the actuator will be performing more than 100,000 cycles.

- If more than 100,000 cycles will be performed, an oil mist lubricator is recommended.^{1,2}
 - Use oil type VG32 Class in temperature range from 15 to 158°F
 - Set oil mist lubricator to lowest setting.

3.4 Travel Adjustment

The 3K Rack & Pinion Actuators have travel stop adjustments in both the clockwise and counterclockwise directions. A 5° degrees overtravel feature provides adjustments from -5° to +5° at the 0° clockwise position, and from 85° to 95° at the 90° counterclockwise position.

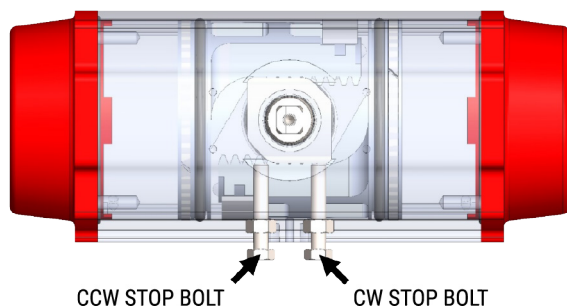

Figure 1: Stop Bolts

All actuated valves require accurate travel-stop adjustments at both ends of the stroke to obtain optimum performance and valve seat life. The accumulation of tolerances in the adaptation of actuators to valves is such that there must be a range of adjustment for both ends of the stroke to achieve the expected performance. See the valve manufacturer's IOM on how the travel should be adjusted. The following are typical features seen:

- **Ball & Plug Valves:** require precise adjustment at the open and closed position. This is to protect the seat from the flow media and to assure absolute shut-off in the closed position.
- **Butterfly Valves:** require precise adjustment at the open and closed position. This is to assure full shut-off, to prevent disc overtravel which can damage the seat in the closed position, and to assure maximum flow in the open position.
- **Tee Assemblies:** where two valves are operated in tandem through a single operator, (3-way configuration) require precise adjustment at both ends of the stroke. This is to assure the seating of both valves.

¹ If a Rack & Pinion Actuator has been in operation with oil mist lubrication, it cannot be discontinued.

² If the actuator is equipped with a pneumatic positioner or controller, oil mist lubricated air shall not be used unless the instrument manufacturer indicates that used instrument is compatible with lubricated air.

4. Operation

4.1 Double Acting Operation:

CCW:

Air is supplied to Port A forcing the pistons away from each other (toward ends) which rotates the drive pinion counterclockwise and exhausts the air out of Port B.

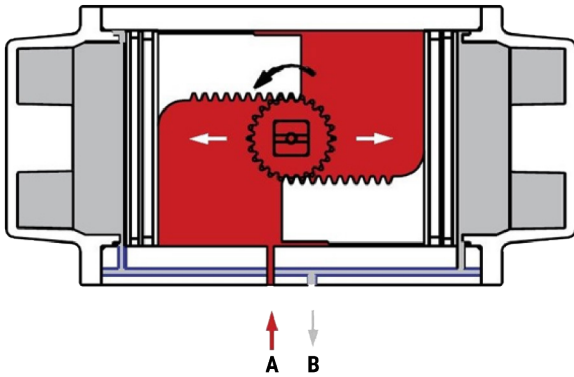

Figure 2: DA - CCW

CW:

Air is supplied to Port B forcing the pistons toward each other (toward center) which rotates the drive pinion clockwise and exhausts the air out of Port A.

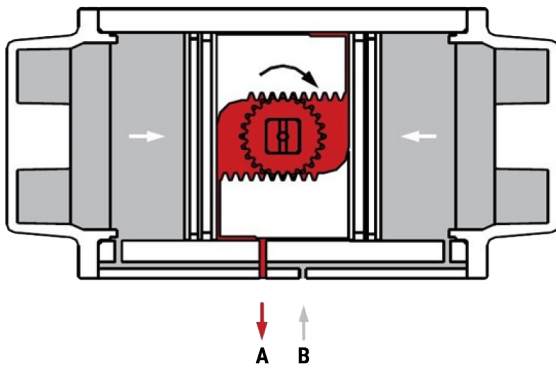

Figure 3: DA - CW

4.2 Spring Return Operation

CCW (Fail CW):

Air is supplied to Port A forcing the pistons away from each other (toward ends), which rotates the drive pinion counterclockwise, compresses the springs and exhausts air out of Port B.

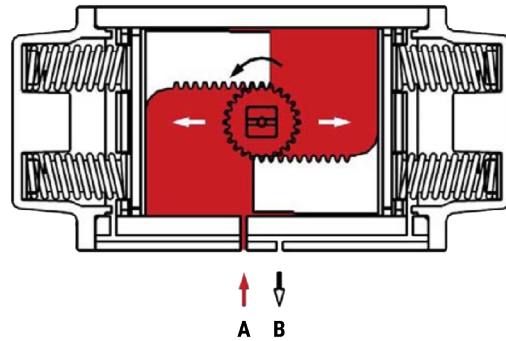

Figure 4: SR - CCW (FAIL CW)

CW (Fail CW):

Air failure (loss of pressure) allows the compressed springs to force pistons toward each other (toward center), which rotates the drive pinion clockwise and exhausts air out of Port A.

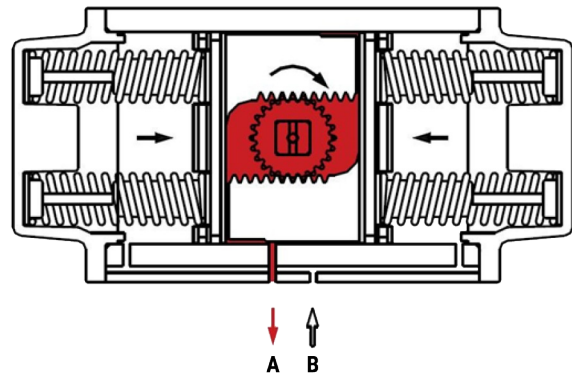

Figure 5: SR - CW (FAIL CW)

Note: 3K Rack & Pinion Actuators are capable of failure in counterclockwise direction by reversing pistons inside of housing. See Section 6 Assembly Instructions

5. Disassembly Procedures

5.1 Removal of Travel Stops

1. Disconnect air supply and electric to relieve any pressure on the actuator.
2. Release the lock nuts and unscrew both travel stops and seals, which are located at the top of the actuator body on the side. See figures 6 and 7.

Note: In the case of spring return valves make sure that the actuator is in the failed position before removing the actuator.

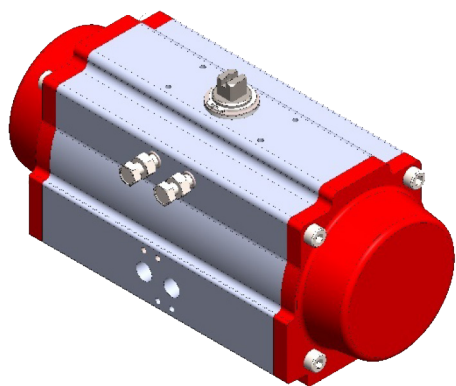

Figure 6: Releasing Lock Nuts

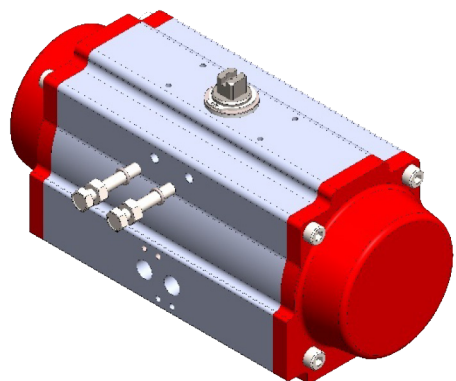

Figure 7: Remove Stop Bolts

5.2 Removal of End Caps

5.2.1 Spring Return Units:

1. Loosen all end cap bolts evenly, to allow the springs to push the end caps out from the body. The springs are contained on spools and the tension will be relaxed when the end cap is removed. See figure 8.

Note: Always use caution when removing springs.

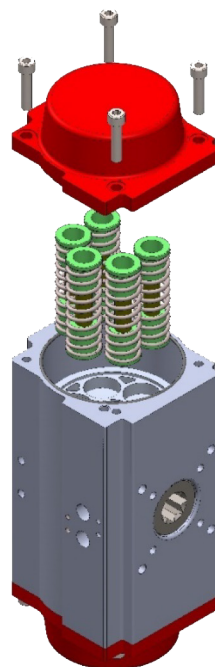

Figure 8: SR End Cap Removal

5.2.2 Double Acting Units:

1. Loosen and remove the end cap bolts evenly on both end caps. See figure 9.

Note: A rubber mallet can be used cautiously to slightly rotate the end cap to gain access to an edge for removal.

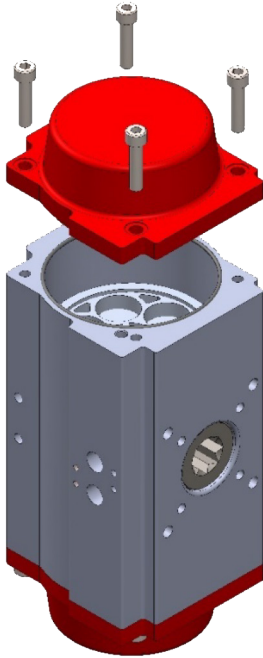

Figure 9: DA End Cap Removal

5.3 Removal of Pistons

1. Rotate the pinion using a wrench on the top pinion square to drive the pistons apart until they are free of the actuator body. See figure 10.

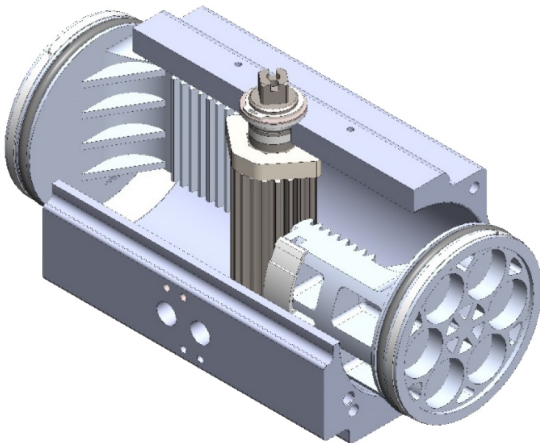

Figure 10: Removing Pistons

5.4 Removal of Pinion

1. Remove the snap ring, thrust washer and thrust bearing from the top of the pinion. See figure 11.

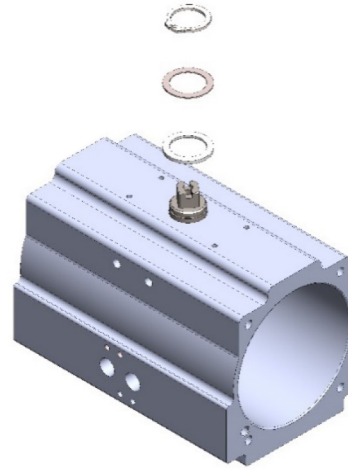

Figure 11: Snap Ring, Thrust Washer and Thrust Bearing

2. Carefully remove the pinion from the cylinder body through the bottom.
 - a. The travel stop cam will not fit through the bottom bore. It will slip off the pinion prior to the pinion removal. See figures 12 and 13.

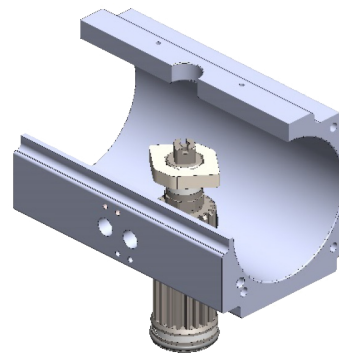

Figure 12: Pinion Removal

- b. Take care to ensure the pinion does not damage the body

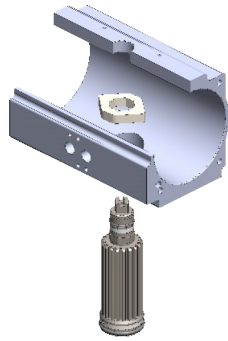

Figure 13: Pinion Removal

6. Assembly Instructions

6.1 Inspection

Check that all components are clean and have not been damaged. ASC recommends that all O-rings, Bearings, Washers, etc. are replaced using only Series-228 replacement parts.

6.2 Installing the Pinion

1. Lightly grease the pinion, O-ring grooves and guide bushing groove of the pinion and pinion O-rings with multi-purpose grease.
2. Install the top bearing into the actuator body bearing bore.
3. Fit the top O-ring into the top pinion groove.
4. Fit the bottom guide bushing into the bottom pinion groove.
5. Slip the bottom O-ring into the bottom pinion groove.
6. Carefully insert the pinion into the body until the top of the pinion is inside the body cylinder.
7. Fit the travel stop cam over the top of the pinion and slide it down until it is engaged with the pinion.
8. Gently push the pinion up through the body making sure the bottom guide bushing, bottom O-ring & top O-ring stay in their grooves.
9. With the pinion in this position install the thrust bearing washer, the thrust washer and lastly the snap ring. Make sure the snap ring fits properly in the groove.

6.3 Alignment of Pinion for Correct Piston Installation:

Rotate the pinion to the position shown in Figure 14 or 15 ensuring that the machined stop flats on the stop collar are in the correct orientation.

Note: When converting from DA/SC to DR/SO or vice versa, the pinion needs to rotate 180° for the stop collar to line up with stop bolts. A red line has been added to Figure 14 and 15 for reference to show the 180° rotation as not all 3K stop collars are symmetrical.

6.4 Installing the Pistons

1. Lightly grease the piston O-rings, piston backup ring & guide plate with multi-purpose grease & fit the O-rings, backup ring & guide plate into their respective grooves on the piston.
2. Liberally grease the actuator body bore and the piston rack.
3. Insert the 2 pistons into the cylinder with the teeth facing each other as shown. See figures 14 and 15.

Note: The position of the piston determines the fail rotation of the actuator. See figure 2, 3, 4 and 5 for reference

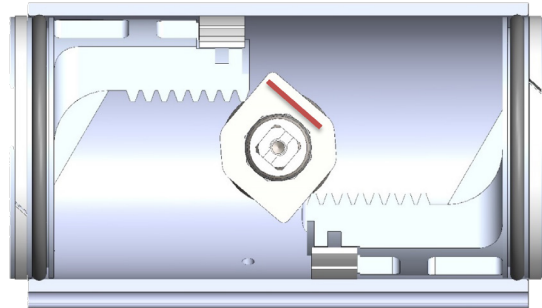

Figure 14: Fail Clockwise

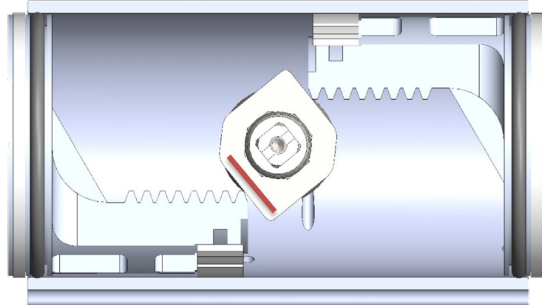

Figure 15: Fail Counter-Clockwise

4. Push both pistons together, into the actuator body, until they are contacting the pinion. Continue to push the pistons together forcing the pinion to rotate clockwise for DA/SC, counterclockwise for DR/SO, until the pistons are drawn together.

Note: When the pistons are together and the racks are correctly engaged with the pinion, the top pinion drive flats should be several degrees past perpendicular to the body for DA/SC, and parallel to the body for DR/SO.

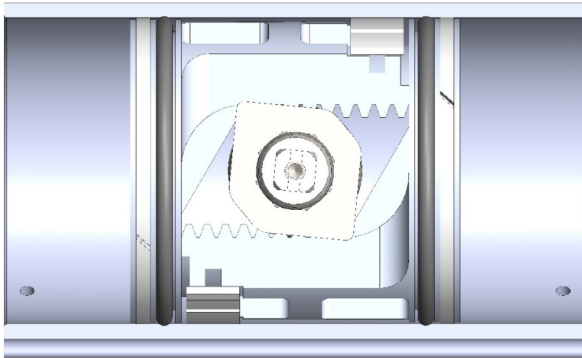

Figure 16: DA/SR

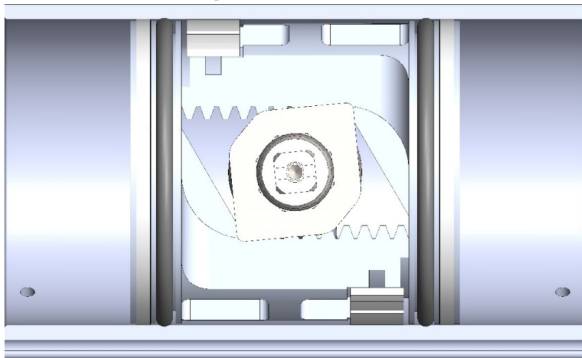

Figure 17: DR/SO

6.5 Installing the Travel Stops:

1. With the pistons together, screw in the corresponding travel stop assembly complete with nut, washer and seal until it comes into contact with the pinion.
2. Rotate the pinion 90 degrees to drive the pistons apart and screw in the other travel stop until it comes into contact with the pinion.

Note: After the end caps are installed (see below) final adjustment is easily made when the actuator has been mounted to its valve, damper or other device, depending on individual requirements. Ensure the nuts are tightened against washer and seal.

6.6 End Cap Installation

1. With the pistons together, lightly grease the end cap O-rings with multi-purpose grease. Grease the ends of the body bore and the end caps.
2. Install the O-rings into the groove in the end caps.

6.6.1 Spring Return Unit

Install the correct number of springs for the desired torque output. Place the springs into the pockets of the piston and end cap. Balance the springs across the pistons

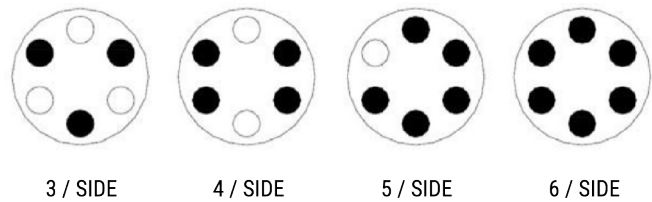

7. Testing

Using compressed air at 80psi-100psi, check the seal areas with soapy water and ensure no bubbles are produced and that the pinion rotates smoothly over its full travel.

8. Cycling of Infrequently Used or Stored Actuators

Actuators that are not in current use for at least a 3-month period, should be cycled a minimum of ten times. The seal manufacturers recommend this procedure to prevent pre-set of the seals.

9. Bill of Materials

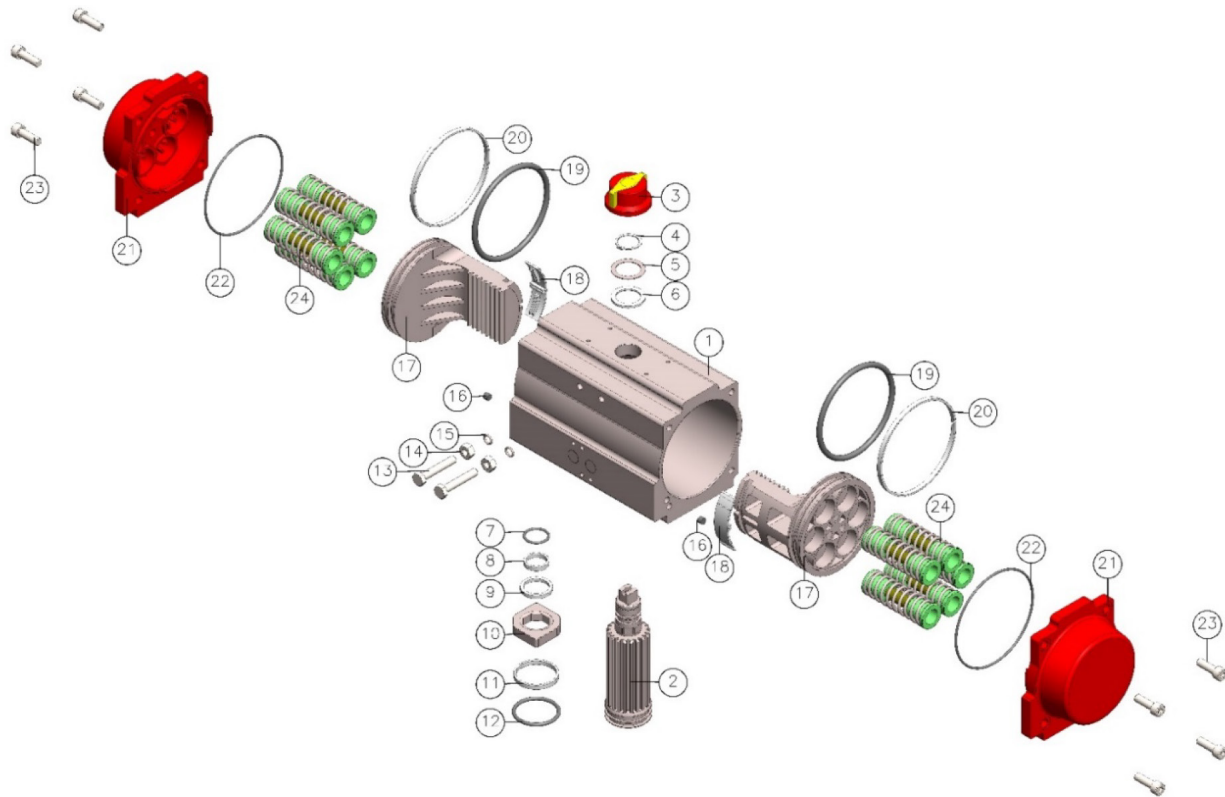

Parts & Materials – Rack & Pinion sizes 10 to 2400, plus 2700 & 3300

No.	Description	Qty.	Standard Material	Options	Repair Kit
1	Cylinder Body	1	Hard Anodized Aluminum (AL6005-T5)		
2	Pinion	1	Zinc/Chromate Plated Carbon Steel		
3	Position Indicator	1	Acrylonitrile Butadiene Styrene (ABS)		
4	Snap Ring	1	Electroless Nickel Plated Steel		
5	Pinion SST Washer	1	304 Stainless Steel		✓
6	Pinion Washer	1	Polyoxymethylene (POM)		✓
7	Top Pinion O-Ring	1	Nitrile Buna (NBR)	Viton® (FKM) or Silicone	✓
8	Top Pinion Bushing - A	1	Nylon (A66)		✓
9	Top Pinion Bushing - B	1	Nylon (A66)		✓
10	Travel Stop Cam	1	Nickel Phosphorus Coated 4# Alloy Steel		
11	Bottom Pinion Bushing	1	Nylon (A66)		✓
12	Bottom Pinion O-Ring	1	Nitrile Buna (NBR)	Viton® (FKM) or Silicone	✓
13	Travel Stop Bolt	2	304 Stainless Steel		
14	Travel Stop Nut	2	304 Stainless Steel		
15	Travel Stop O-Ring	2	Nitrile Buna (NBR)		✓
16	Hole Sealant	2	Nitrile Buna (NBR)	Viton® (FKM) or Silicone	✓
17	Piston	2	Anodic Oxidation Film Die Cast Aluminum		
18	Guide Plate	2	Nylon (A66)		✓
19	Piston O-Ring	2	Nitrile Buna (NBR)	Viton® (FKM) or Silicone	✓
20	Piston Guide Band	2	Nylon (A66)		✓
21	End Cap	2	Epoxy Coated Die Cast Aluminum		
22	End Cap O-Ring	2	Nitrile Buna (NBR)	Viton® (FKM) or Silicone	✓
23	End Cap Bolt	2	304 Stainless Steel		
24	Spring Cartridge	*	Epoxy Coated Spring Steel		

* Spring quantity can range from 2 to 6 per side.

10. Spare Parts

Actuator Size	Buna Repair Kit -20°F to 175°F	Viton Repair Kit 0°F to 300°F	Silicone Repair Kit -58°F to 175°F	Spring Cartridges (each)
3K-40	3RKB0040	3RKV0040	3RKL0040	3R-SP40
3K80	3RKB0080	3RKV0080	3RKL0080	3R-SP80
3K130	3RKB0130	3RKV0130	3RKL0130	3R-SP130
3K200	3RKB0200	3RKV0200	3RKL0200	3R-SP200
3K300	3RKB0300	3RKV0300	3RKL0300	3R-SP300
3K500	3RKB0500	3RKV0500	3RKL0500	3R-SP500
3K700	3RKB0700	3RKV0700	3RKL0700	3R-SP700
3K850	3RKB0850	3RKV0850	3RKL0850	3R-SP850
3K1000	3RKB1000	3RKV1000	3RKL1000	3R-SP1000
3K1200	3RKB1200	3RKV1200	3RKL1200	3R-SP1200
3R1750	3RKB1750	3RKV1750	3RKL1750	3R-SP1750
3R2400	3RKB2400	3RKV2400	3RKL2400	3R-SP2400
3R2700	3RKB2700	3RKV2700	3RKL2700	3R-SP2700
3R3300	3RKB3300	3RKV3300	3RKL3300	3R-SP3300

11. Service

It is the policy of ASC to give the best possible service to our customers. We are happy to assist you in any way we can and if you have any questions about Series-228 actuators or other ASC products. Please contact ASC or your local ASC distributor for additional information. www.asc-es.com

About ASC Engineered Solutions

ASC Engineered Solutions connects high-quality products with advanced technology, service, and support. With nearly 2,000 employees, the company's extensive portfolio of precision-engineered piping support, valves and connections provides products to professionals across industries, such as commercial and residential construction, industrial, fire protection, and oil and gas. Its portfolio of leading brands includes ABZ Valve®, AFCON®, Anvil®, Anvil EPS, Basic-PSA, Beck®, Catawissa, Cooplet®, FlexHead®, FPPI®, Gruvlok®, J.B. Smith, Merit®, NAP®, Quadrant®, SCI®, Sharpe®, SPF®, SprinkFLEX®, Trenton Pipe, VEP, and WARDFlex®. With headquarters in Oak Brook, IL, ASC also has ISO 9001:2015 certified production facilities in PA, TN, IL, TX, AL, KS, and RI.



**A World of Solutions.
Let's Find *YOURS.***

Valves, Actuation & Controls - Grooved, Threaded & Press Systems
Hangers & Supports - Seismic Bracing - Flexible Sprinkler & Gas Systems



asc-es.com

Building Connections That Last™

FC-IOM-20C QVA-v02 20250610

